

SIREN SPEAKERS

Project-A-Flex. Speaker horn and driver may be installed separately under the bonnet of even the most compact of vehicles. 1.5m acoustical tube connects the speaker horn to the driver. Complete with 100W RMS driver and mounting kit. Also available as a kit for use with customer supplied drivers. Weight 4.5kg

Part Number (kit with driver): PROJECT

Part Number (for use with customer supplied drivers): PROJECTKT

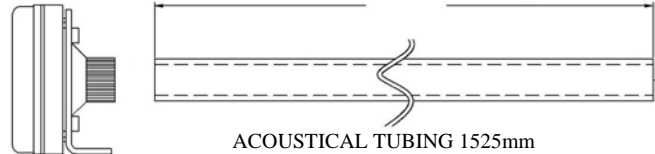

SPEAKER DRIVER

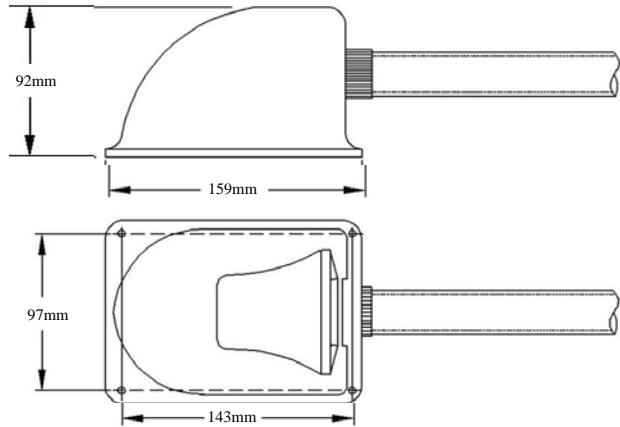

With the continued development of new cars and compact engine size, available space under the bonnet is more limited than ever before. The UST has been specifically designed with this in mind utilising minimal space availability. Weight 5kg

Part Number (kit with driver): UST

Part Number (for use with customer supplied drivers): USTKT

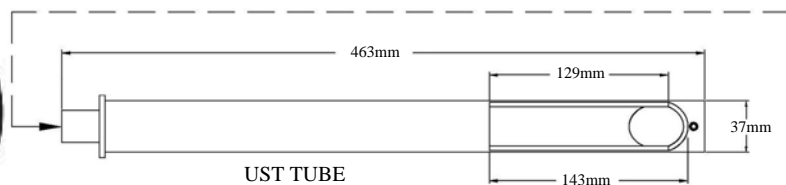
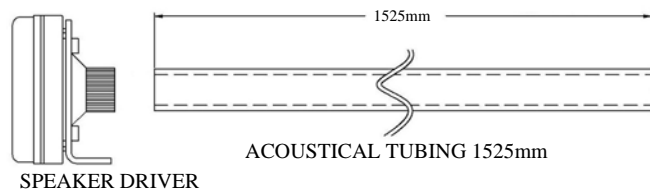

The licensed manufacturer for
European Certified
WHELEN[®]
products



WOODWAY[®]
Woodway Engineering Limited

Woodway Engineering Ltd., Lower Road, Barnacle, Coventry, CV7 9LD

Phone: 02476 841750

Fax: 02476 621796

e-mail: woodway@btconnect.com

www.woodwayengineering.co.uk