

NIGHT OWL



Designed for frequent and reliable use in the most demanding of conditions. The Night Owl is used extensively by Fire Services on front line Pumping Appliances & Command Vehicles throughout the world. The compact, low profile, Night Owl System can also be quickly installed onto most passenger, 4x4 or light commercial vehicles using custom designed aluminium roof mounting bars. Night Owl stows horizontally on the vehicle roof. When operated the mast raises to the vertical and extends via compressed air to over 2m in height. Floodlighting heads are available in vehicle voltage Super-LED & 70W Metal Halide or 110/220V Linear Halogen 300W or 500W.

FEATURES:

- Heavy Duty stainless steel chassis.
- Driver visual & audible mast raised alarm.
- Auto park on handbrake release.
- Auto park when power is switched on if the mast has been left raised.
- LED matrix status display and low voltage warning on handset.
- 4 wire handset connection via quick connect sealed connector.
- Low profile & compact mounting footprint, 2m extended height.
- Unique system 'arm' procedure to prevent accidental operation.
- Auto/Manual override switch for emergency stowing & personal safety during maintenance.
- Long life low current draw PIONEER Super-LED lights or Metal Halide 70W vehicle voltage lighting.
- High speed pan/tilt action quickly directs scene lighting to the required area.
- Optional mast head mounted strobe or Super-LED beacon. Split colour beacon for command vehicle identification available.

Pioneer LED Floodlights are now available on the Woodway Night Owl Mast Systems



Night Owl Mast Systems



WOODWAY®
Woodway Engineering Limited









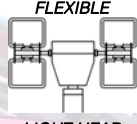
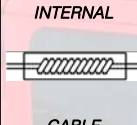

The licensed manufacturer for
European Certified
WHELEN®
products

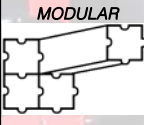
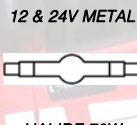
Woodway Engineering Ltd., Lower Road, Barnacle, Coventry, CV7 9LD
Phone: 02476 841750 Fax: 02476 621796 e-mail: woodway@btconnect.com www.woodwayengineering.co.uk

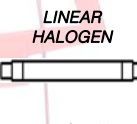
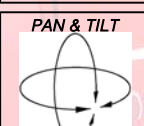
NIGHT OWL

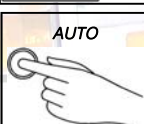
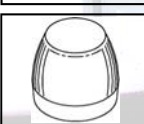
The Night Owl has the following features or options

<p>24 VDC</p>	<p>Available in 24VDC for Commercial Vehicle applications such as Fire Appliances & Incident Command Vehicles.</p>	<p>FLEXIBLE LIGHT HEAD</p> 	<p>Lights can be installed in various configurations including just on one side to clear ladders and other roof mounted equipment.</p>
<p>12 VDC</p>	<p>Available in 12VDC for light commercial vehicle, van, 4X4 & car applications. Ideal when used with PIONEER Super-LED Floodlights.</p>	<p>INTERNAL CABLE</p> 	<p>On most masts, the cables powering the mast head are enclosed inside the mast tubes. (Not with 110/220V lights).</p>
<p>STAINLESS STEEL CHASSIS</p> 	<p>Laser cut stainless steel chassis for long service life. Heavy duty white powder coat finish.</p>	<p>12 & 24V LED PIONEER</p> 	<p>All new Vehicle voltage Whelen PIONEER Super-LED floodlights with individual lamp adjustment. Available in 12 & 24VDC.</p>
<p>MODULAR CONSTRUCTION</p> 	<p>Modular construction allows for ease of servicing & maintenance.</p>	<p>12 & 24V METAL HALIDE 70W</p> 	<p>Vehicle voltage 70W Metal Halide lamps with instant hot re-strike. Available in 12 & 24VDC.</p>
<p>HEAVY DUTY CONTROLLER</p> 	<p>Heavy duty hand held controller with water proof switches allows all mast functions to be operated by a gloved hand.</p>	<p>LINEAR HALOGEN 110/220V</p> 	<p>Linear Halogen, 300W & 500W 110V or 220V light heads. High voltage cable is routed via an external coiled suzi tube.</p>
<p>PAN & TILT LIGHT HEAD</p> 	<p>Fast, smooth 340 degree pan & tilt control from handset. Typically 11 seconds for full rotation & tilting of the light head.</p>	<p>e11</p> 	<p>Approved to the European Vehicle EMC Directive, 2004/104, the Machinery Directive and is CE Marked.</p>
<p>MAST RAISED WARNING</p> 	<p>Mast Raised alarm to warn the driver should the mast be raised while attempting to drive. Automatic stow on handbrake release.</p>	<p>2 YEAR WARRANTY</p>	<p>Comprehensive 2 year warranty on the mast and Metal Halide light heads.</p>
<p>AUTO PARK</p> 	<p>Comprehensive safety features to prevent unintentional operation and automatic stowage. Manual/Auto switch for added operator safety when servicing.</p>	<p>5 YEAR WARRANTY</p>	<p>5 year warranty on PIONEER Super-LED Scene & Spot Lights.</p>
	<p>Optional mast head mounted strobe or Super-LED beacon. Split colour for command vehicle identification available.</p>		<p>UK Designed & Manufactured.</p>



WOODWAY®
Woodway Engineering Limited



Woodway Engineering Ltd., Lower Road, Barnacle, Coventry, CV7 9LD

Phone: 02476 841750 Fax: 02476 621796 e-mail: woodway@btconnect.com www.woodwayengineering.co.uk

NIGHT OWL



- Heavy duty hand held controller with water proof switches allows all the mast functions to be easily operated by a gloved hand.
- Momentary action, sealed colour coded push buttons. Buttons cannot be accidentally left in an on state.
- Single operation mast stowing with automatic head positioning. Mast extension may be stopped at any point leaving the mast partly raised if height is restricted.
- Auto parking on hand brake release and on power off.
- Simplified wiring requires only four low current wires to connect between the handset and Night Owl mast. Connection is made by waterproof connectors.
- Red LED matrix displays system status including 'Low Voltage' condition.
- Unique system 'arm' procedure prevents accidental operation.

LIGHT HEAD TYPE	ADD TO HEIGHT
4 X PIONEER PFA1/PFP1	90mm
2 x METAL HALIDE 70W	22mm
4 X METAL HALIDE 70W	160mm
4 X 300W/500W HALOGEN	122mm

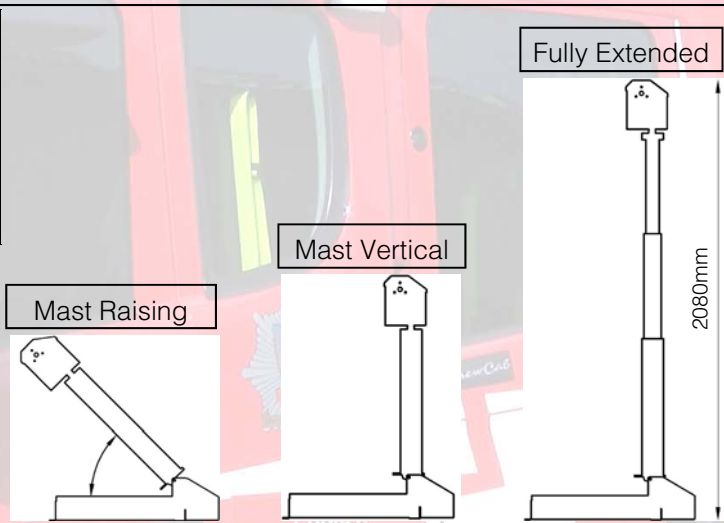

Due to the customisable nature of the Night Owl, the extended height is to the top of the light head only. Please use the table opposite for the height modifiers for different assemblies types. Any assembly not included in the table requires no modification to the extended height.

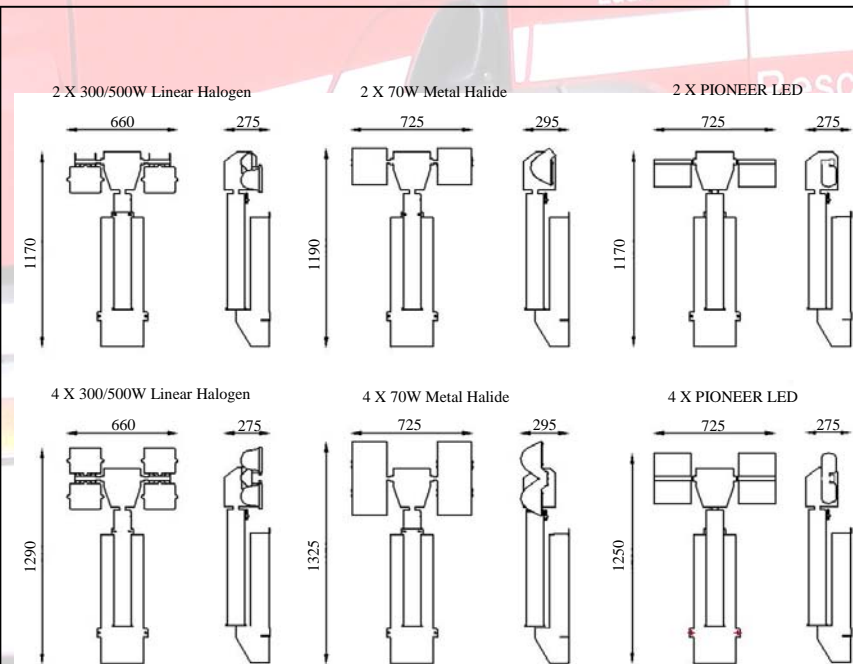

Mast raised from park position to vertical	10 secs
Mast vertical to fully raised	12 secs
Full 340 degree pan	10 secs
Full 340 degree tilt	11 secs
Mast lowered from fully raised to parked position	30 secs
Approximate weight	50kgs

*To request a full installation manual
Please contact the Factory*

Night Owl Mast Systems



WOODWAY®
Woodway Engineering Limited



The licensed manufacturer for
European Certified
WHELEN®
products



RUGGED...RELIABLE...
BRILLIANT!



Pioneer Floodlights are now available on the Woodway



Mast Systems

Individual light heads may be manually adjusted for tilt angle to optimize light distribution

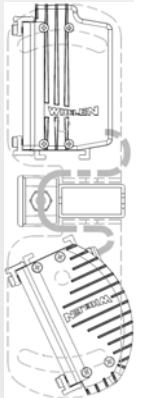

When PIONEER Floodlights (patent pending) puts all the performance and LED technology into a package producing area scene and focused spot light illumination.

Designed for Heavy Duty use over a prolonged period of time they provide a high level of area scene lighting with low vehicle current draw.

Pioneer Light heads are RUGGED, RELIABLE & BRILLIANT.

FEATURES:

- Solid-State electronics and lamp source are proven reliable and durable and eliminate the high cost of lamp or ballast replacements.
- Pioneer LED flood lights are instant on/off eliminating the high current in-rush and warm up time associated with other light sources.
- Rugged aluminium housing.
- Pioneer LED flood lights do not emit ultra violet radiation that attracts insects during night time operation.
- HDP® Heavy-Duty Professional 5 year warranty.
- Available in 12 or 24 volts.
- Low current draw, 24V PFA1 Series draws only 1.5 amps & PFP1/PSP1 Series draws only 3 amps each.

Pioneer™ Lighthouse

12 VDC	24 VDC
e11 ✓	5 YEAR WARRANTY



The licensed manufacturer for European Certified
WHELEN
products



WOODWAY®
Woodway Engineering Limited

Woodway Engineering Ltd., Lower Road, Barnacle, Coventry, CV7 9LD

Phone: 02476 841750 Fax: 02476 621796 e-mail: woodway@btconnect.com www.woodwayengineering.co.uk

NIGHT OWL

Night Owl Mast Systems

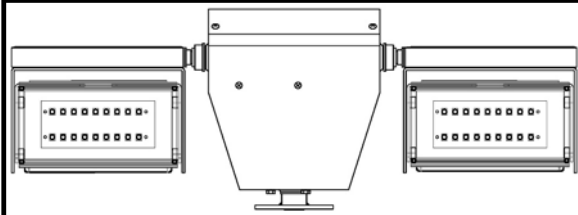

Entry level Night Owl Pioneer head, 2 x PFA1 lights provide near proximity scene illumination.
 Current draw @ 24V: 3 AMPS.
 Light Output: 6720 Lumens



70m
46m
30m
15m



TWO PFA1 LIGHT HEADS
 3 Amps @ 24VDC

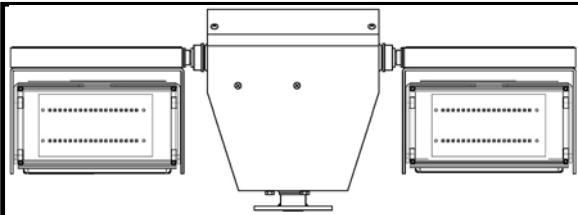

Increased scene illumination with 2 x PFP1 Light heads.

Current draw @ 24V: 6 AMPS.
 Light Output: 15600 Lumens



70m
46m
30m
15m

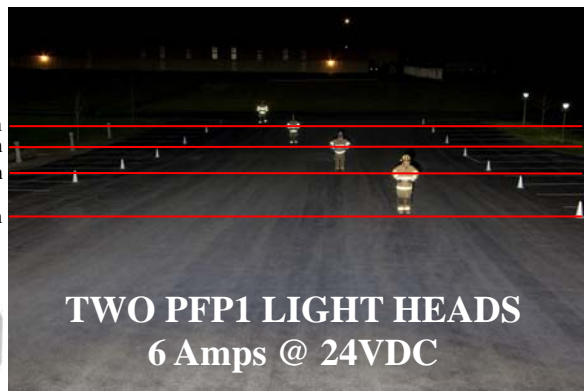

TWO PFP1 LIGHT HEADS
 6 Amps @ 24VDC

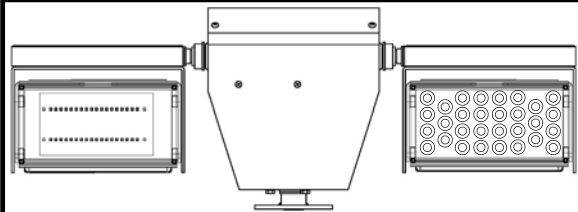

Recommended configuration providing a combination of area scene (PFP1) and focused 8° spot (PSP1) light illumination.
 Current draw @ 24V: 6 AMPS.
 Light Output: 15600 Lumens



70m
46m
30m
15m

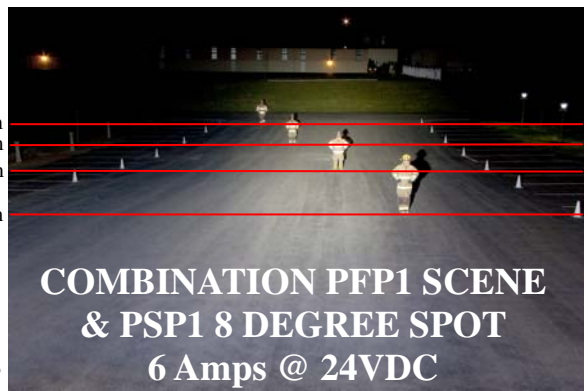

COMBINATION PFP1 SCENE & PSP1 8 DEGREE SPOT
 6 Amps @ 24VDC

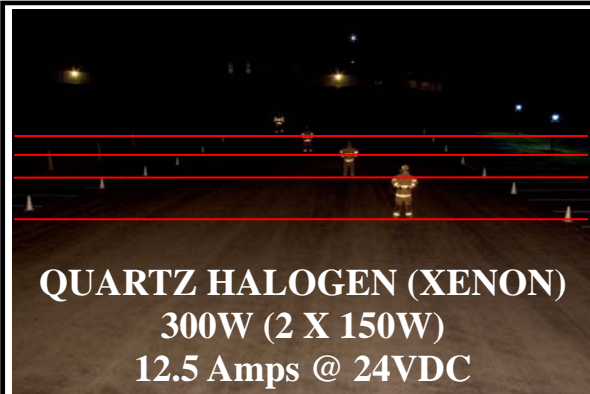

QUARTZ HALOGEN (XENON)
 300W (2 X 150W)
 12.5 Amps @ 24VDC

70m
46m
30m
15m

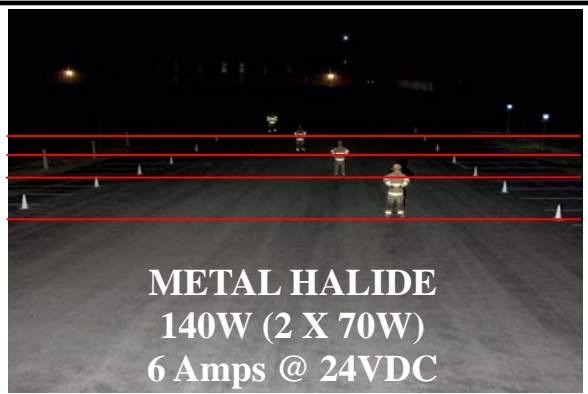

METAL HALIDE
 140W (2 X 70W)
 6 Amps @ 24VDC



WOODWAY®
 Woodway Engineering Limited



PART NUMBER	VDC	DESCRIPTION
NO4-2\$00C-12	12	Night Owl, 12VDC with 2, 300/500W** Linear Halogen lights. Integral air compressor system. External coiled cable for light heads power supply.
NO4-4\$00C-12	12	Night Owl, 12VDC with 4, 300/500W** Linear Halogen lights. Integral air compressor system. External coiled cable for light heads power supply.
NO4-2MHC-12	12	Night Owl, 12VDC with 2, 70W Metal Halide lights. Integral air compressor system.
NO4-2PFA1C-12	12	Night Owl, 12VDC with 2, PIONEER PFA1 Super-LED lights. Integral air compressor system.
NO4-4PFA1C-12	12	Night Owl, 12VDC with 4, PIONEER PFA1 Super-LED lights. Integral air compressor system.
NO4-4PFZ1C-12	12	Night Owl, 12VDC with 2 x PFA1 & 2 x PFP1 PIONEER Super-LED lights. Integral air compressor system.
NO4-1PCP2C-12	12	Night Owl, 12VDC with 1 x PFP1 & 1 x PSP1 PIONEER Super-LED lights. Integral air compressor system.
NO4-2PCP2C-12	12	Night Owl, 12VDC with 2 x PFP1 & 2 x PSP1 PIONEER Super-LED lights. Integral air compressor system.
NO4-2\$00#-24	24	Night Owl, 24VDC with 2, 300/500W** Linear Halogen lights. Integral air compressor or air regulator system. External coiled cable for light heads power supply.
NO4-4\$00#-24	24	Night Owl, 24VDC with 4, 300/500W** Linear Halogen lights. Integral air compressor or air regulator system. External coiled cable for light heads power supply.
NO4-2MH#-24	24	Night Owl, 24VDC with 2, 70W Metal Halide lights. Integral air compressor or air regulator system.
NO4-4MH#-24	24	Night Owl, 24VDC with 4, 70W Metal Halide lights. Integral air compressor or air regulator system.
NO4-2PFA1#-24	24	Night Owl, 24VDC with 2, PIONEER PFA1 Super-LED lights. Integral air compressor or air regulator system.
NO4-4PFA1#-24	24	Night Owl, 24VDC with 4, PIONEER PFA1 Super-LED lights. Integral air compressor or air regulator system.
NO4-4PFZ1#-24	24	Night Owl, 24VDC with 2 x PFA1 & 2 x PFP1 PIONEER Super-LED lights. Integral air compressor or air regulator system.
NO4-1PCP2#-24	24	Night Owl, 24VDC with 1 x PFP1 & 1 x PSP1 PIONEER Super-LED lights. Integral air compressor or air regulator system.
NO4-2PCP2#-24	24	Night Owl, 24VDC with 2 x PFP1 & 2 x PSP1 PIONEER Super-LED lights. Integral air compressor or air regulator system.
HS4-03-SBL	12/24	Hand Set with 3m wander lead.
HS4-EXT5	12/24	5m handset wander lead to Night Owl extension lead and junction box.
HS4-EXT10	12/24	10m handset wander lead to Night Owl extension lead and junction box.
NORMK2		Night Owl Roof Mounting Kit. (2 bars).
1510*MHMB	12/24	10W Strobe mast head beacon. Replace * with A=Amber, B=Blue, C=Clear, R=Red,
L32*MHMB-12	12	L32 LED mast head beacon, 12V. Replace * with A=Amber, B=Blue, C=Clear, R=Red., RW=Red/White
L32*MHMB-24	24	L32 LED mast head beacon, 24V. Replace * with A=Amber, B=Blue, C=Clear, R=Red, RW=Red/White

Notes:

- # Replace # with A = Air Regulator, C = Air Compressor
- \$ Replace \$ with 3 = 300W lamps or 5 = 500W lamps
- ** Specify lamp voltage 110V or 220V

Other combinations of PIONEER light heads are available by special order.



The licensed manufacturer for
European Certified

WHELEN[®]

products



Woodway Engineering Ltd., Lower Road, Barnacle, Coventry, CV7 9LD

Phone: 02476 841750 Fax: 02476 621796 e-mail: woodway@btconnect.com www.woodwayengineering.co.uk