

# L51 & L52 SERIES BEACONS

LED Beacons

360° SUPER-LED Self Contained Beacon



Super-LED secondary warning beacon with SignalAlert™ flash pattern. L51 & L52 features exclusive side-emitting LED technology that rivals strobe in intensity with lower amp draw. LED light source has a rated life that exceeds that of comparable flash tubes by more than 100:1.

**FEATURES:**

- Low current draw.  
L51: 0.6 amp average @ 12.8 VDC.  
L52: 0.75 amp average @ 12.8 VDC.
- 15 Scan-Lock flash patterns. Signal Alert is the default factory programmed pattern.
- SmartLED® beacon design.
- Compact size, universal application.
- Polycarbonate base & dome.
- Virtually no EMI radiation.
- Supplied with 150mm pigtail (permanent mount) or 3m cord with cigar plug and On/Off switch with LED "On" indicator (magnetic mount).

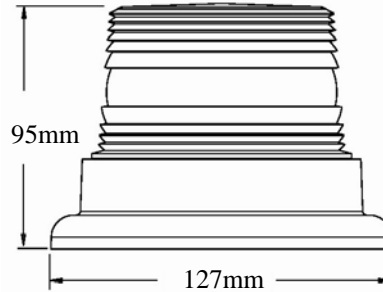

Dimensions in mm

**Flash Patterns:**

- SignalAlert™ 75
- SignalAlert™ 150
- Single 75
- Single 150
- Single 375
- Double 75
- Double 150
- Comet Flash® 75
- ActionFlash™
- ModuFlash™
- ComAlert™
- ActionScan™
- SignalAlert Steady
- SteadyBrake
- Steady, 10% Duty



<b>12 VDC</b>	<b>e11</b> ✓	<b>5 YEAR WARRANTY</b>
-------------------	-----------------	--------------------------------

<b>L51*P</b>	<b>12V</b>	L51 Permanent mounting
<b>L51*M</b>	<b>12V</b>	L51 Magnetic mounting
<b>L52*P</b>	<b>12V</b>	L52 Permanent mounting
<b>L52*M</b>	<b>12V</b>	L52 Magnetic mounting

Replace asterisk (\*) in model numbers with letter indicating colour choice.  
A = Amber LED and amber dome  
C = White LED and clear dome

Available in Amber and White/clear only.

Due to variations in vehicle surfaces and operating conditions, the use of any magnetic mounted warning beacon on the vehicle while in motion is at the discretion and risk of the user.



**WOODWAY®**  
Woodway Engineering Limited



The licensed manufacturer for European Certified  
**WHELEN®**  
products

# TEMPORARY MOUNTING

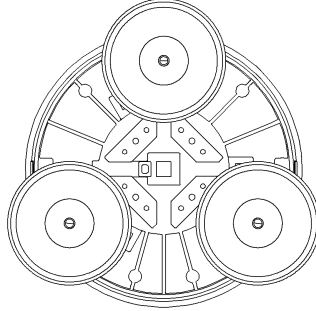
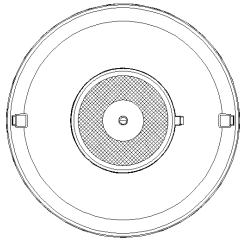
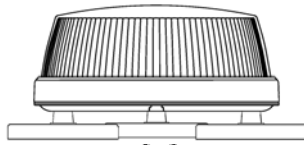
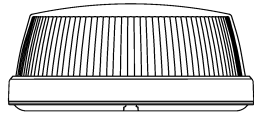

Single Magnet & magnetic/  
Vacuum Mounting  
(Standard Whelen)  
L32L\*M Beacon shown

3 Point Magnetic Mounting  
(L31/L32 UK Specification)  
L32L\*M-UK shown

Whelen magnetic beacons are supplied as standard with a single central mounted magnet (with no neoprene cover) or magnetic/vacuum cup. Under normal operating conditions this will be suitable for low speed and static use.

Where it is intended to use a beacon whilst the vehicle is in motion we recommend the 3 point magnetic fixing.

*Please refer to the warning notice below for more information regarding magnetic attachment of beacons.*

## WARNING

*The use of any magnetically or magnetic/vacuum mounted warning device on the outside of a vehicle in motion is not recommended and is at the sole risk and responsibility of the user.*

Before using a magnetic or vacuum mount beacon on a moving vehicle the following factors noted below should be considered. Each factor will to varying degrees contribute to the magnetic/vacuum adhesion being lost and the beacon becoming detached from the vehicle posing a risk to other road users.

- The higher the speed that the vehicle is travelling the greater the force that will be exerted on the beacon.
- Headwinds, crosswinds, turbulence from other vehicles and forces exerted when cornering, braking or accelerating may exert sudden unpredictable forces on the beacon.
- The surface condition of the vehicle roof due to the presence of water, ice or road contamination will compromise suction and reduce magnetic adhesion and will act as a lubricant that may cause the beacon to move.
- The use of rubber or neoprene magnet caps to prevent scratching of the vehicle roof will reduce the magnetic adhesion force.
- The thinner the gauge of metal used in the manufacture of the vehicle, the lower the magnetic clamping force available.

**WOODWAY®**  
Woodway Engineering Limited



The licensed manufacturer for  
European Certified  
**WHELEN®**  
products



Woodway Engineering Ltd., Lower Road, Barnacle, Coventry, CV7 9LD

Phone: 02476 841750

Fax: 02476 621796

e-mail: [woodway@btconnect.com](mailto:woodway@btconnect.com)

[www.woodwayengineering.co.uk](http://www.woodwayengineering.co.uk)