

# VIPOD



VI POD (6 POD) is a primary warning beacon ideal for use as temporary lighting on Emergency Service covert vehicles & Motorway Maintenance, 4X4, light commercial and construction vehicles. Available in permanent and magnetic mounting, it provides 360° of heavy-duty warning for your vehicle.

- Six LINZ6™ LED modules provide 360 degrees of warning in a compact, versatile housing.
- Rugged LEDs have no glass or filaments to break and are rated for 100,000 hours.
- 12 VDC.
- Self-contained SmartLED® beacon with built-in electronic flasher with 58 Scan-Lock™ flash patterns including steady burn.
- Heavy-duty reinforced thermoplastic housing.
- Low current draw: 2.25 Peak Amp, 0.9 Amp avg. @12.8 VDC, three lamps alternating with three lamps.
- Permanent mount via single 1/2-13 x 1-1/2" stainless steel bolt includes a 5 conductor 18 gauge 6m cable.
- Permanent mount offers low power control, 62 Scan-Lock™ flash patterns and synchronize feature allows multiple units to be wired as a system.
- New dual switch cigar plug allows pattern selection in magnetic mount option
- Five year HDP®, Heavy-Duty Professional warranty.

10-16 VDC	e11 ✓
	5 YEAR WARRANTY

**WARNING:**  
The use of any magnetic or magnetic/suction mounted warning beacon on the vehicle while in motion, is at the discretion and risk of the user.

New dual switch cigar plug allows pattern selection in magnetic and magnetic mount models.

Magnetic and magnetic/vacuum mount models do not offer cruise light, low power or SYNC functions.



Available in Amber and Blue.

**6 POD MINI LIGHTBAR**

**VIPOD™**



**WOODWAY®**  
Woodway Engineering Limited



The licensed manufacturer for European Certified  
**WHELEN®**  
products

# V I P O D

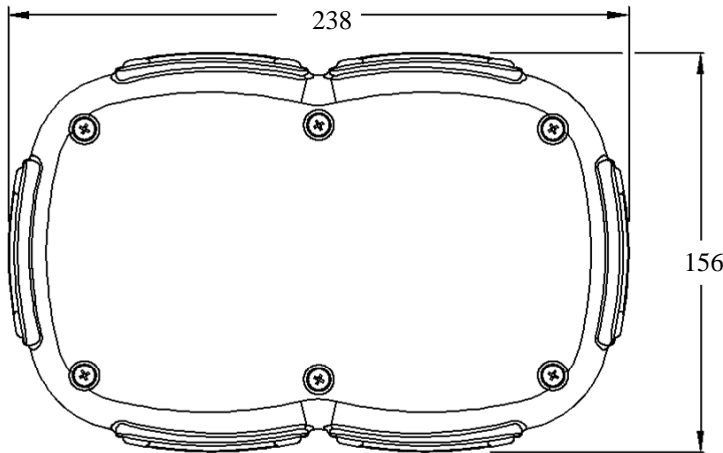

Dimensions in mm

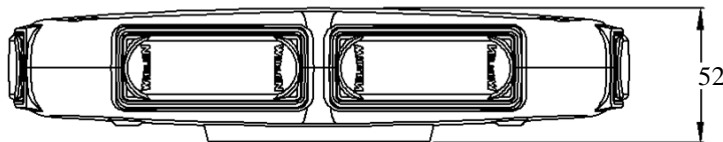

**MODELS:**

- 6PODP\*** ..... Permanent mount
- 6PODM\*-UK** ..... Magnetic mount

Replace " \* " asterisk in model number with desired colour: **A** = Amber; **B** = Blue

**WARNING:**  
*The use of any magnetic or magnetic/suction mounted warning beacon on the vehicle while in motion, is at the discretion and risk of the user.*



Six LINZ6™ LED modules provide 360 degrees of warning in a compact, heavy-duty reinforced thermoplastic housing. LEDs have no glass or filaments to break and are rated for 100,000 hours use providing a rugged & reliable primary warning lighting solution.

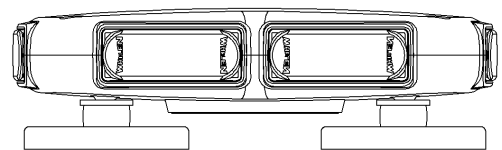
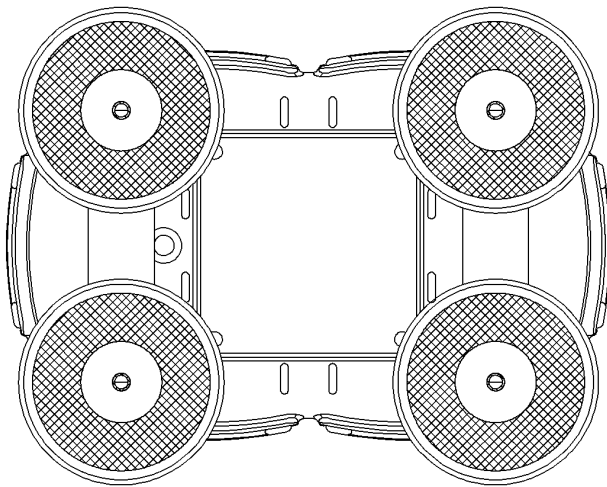

Front/Rear View

Magnetic versions are supplied with four Heavy Duty magnets with automatic roof profile adjustment and protective neoprene covers.



**WOODWAY®**  
 Woodway Engineering Limited

The licensed manufacturer for  
 European Certified  
**WHELEN®**  
 products



Woodway Engineering Ltd., Lower Road, Barnacle, Coventry, CV7 9LD

Phone: 02476 841750

Fax: 02476 621796

e-mail: [woodway@btconnect.com](mailto:woodway@btconnect.com)

[www.woodwayengineering.co.uk](http://www.woodwayengineering.co.uk)